

## PPTC of JK-SMD1210 (L) Series Surface-mount Devices

### Features:

- ✧ RoHS Compliant & Halogen Free
- ✧ Faster tripping, 1210 Dimension, Surface mountable, Solid state
- ✧ Operating Current: 1.5A~7.5A
- ✧ Maximum Voltage: 6V/12V
- ✧ Operating Temperature: -40°C ~ 85°C
- ✧ Certification: CSA

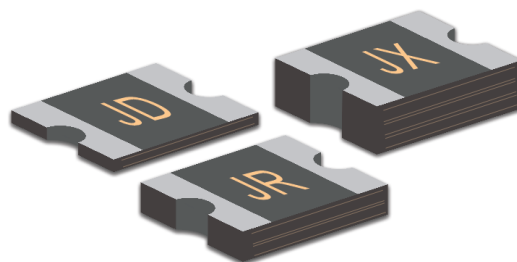

### Product Dimensions (mm)

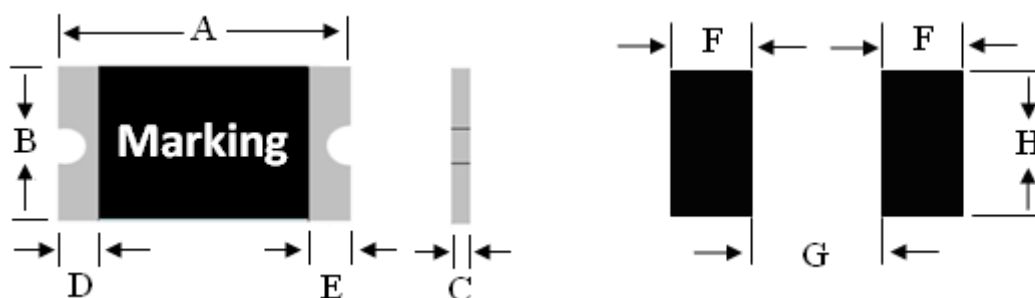

Model	Marking	A		B		C		D	E
		Min	Max	Min	Max	Min	Max	Min	Min
JK-SMD1210-150L	JC	3.0	3.43	2.35	2.8	0.3	0.7	0.25	0.1
JK-SMD1210-150L-12	JC	3.0	3.43	2.35	2.8	0.3	0.7	0.25	0.1
JK-SMD1210-175L	JC	3.0	3.43	2.35	2.8	0.3	0.7	0.25	0.1
JK-SMD1210-175L-12	JC	3.0	3.43	2.35	2.8	0.3	0.7	0.25	0.1
JK-SMD1210-190L	JD	3.0	3.43	2.35	2.8	0.3	0.7	0.25	0.1
JK-SMD1210-190L-12	JD	3.0	3.43	2.35	2.8	0.3	0.7	0.25	0.1
JK-SMD1210-200L	JD	3.0	3.43	2.35	2.8	0.3	0.7	0.25	0.1
JK-SMD1210-200L-12	JD	3.0	3.43	2.35	2.8	0.3	0.7	0.25	0.1
JK-SMD1210-260L	JO	3.0	3.43	2.35	2.8	0.4	1.0	0.25	0.1
JK-SMD1210-260L-12	JO	3.0	3.43	2.35	2.8	0.4	1.0	0.25	0.1
JK-SMD1210-300L	JO	3.0	3.43	2.35	2.8	0.4	1.0	0.25	0.1



Model	Marking	A		B		C		D	E
		Min	Max	Min	Max	Min	Max	Min	Min
JK-SMD1210-300L-12	JO	3.0	3.43	2.35	2.8	0.4	1.0	0.25	0.1
JK-SMD1210-350L	JO	3.0	3.43	2.35	2.8	0.4	1.2	0.25	0.1
JK-SMD1210-350L-12	JO	3.0	3.43	2.35	2.8	0.4	1.2	0.25	0.1
JK-SMD1210-380L	JR	3.0	3.43	2.35	2.8	0.4	1.2	0.25	0.1
JK-SMD1210-380L-12	JR	3.0	3.43	2.35	2.8	0.4	1.2	0.25	0.1
JK-SMD1210-400L	JR	3.0	3.43	2.35	2.8	0.5	1.2	0.25	0.1
JK-SMD1210-400L-12	JR	3.0	3.43	2.35	2.8	0.5	1.2	0.25	0.1
JK-SMD1210-450L	JR	3.0	3.43	2.35	2.8	0.5	1.4	0.25	0.1
JK-SMD1210-450L-12	JR	3.0	3.43	2.35	2.8	0.5	1.4	0.25	0.1
JK-SMD1210-500L	JP	3.0	3.43	2.35	2.8	0.5	1.4	0.25	0.1
JK-SMD1210-500L-12	JP	3.0	3.43	2.35	2.8	0.5	1.4	0.25	0.1
JK-SMD1210-550L	JP	3.0	3.43	2.35	2.8	0.5	1.4	0.25	0.1
JK-SMD1210-550L-12	JP	3.0	3.43	2.35	2.8	0.5	1.4	0.25	0.1
JK-SMD1210-600L	JT	3.0	3.43	2.35	2.8	0.5	1.6	0.25	0.1
JK-SMD1210-600L-12	JT	3.0	3.43	2.35	2.8	0.5	1.6	0.25	0.1
JK-SMD1210-650L	JT	3.0	3.43	2.35	2.8	0.5	1.6	0.25	0.1
JK-SMD1210-650L-12	JT	3.0	3.43	2.35	2.8	0.5	1.6	0.25	0.1
JK-SMD1210-700L	JX	3.0	3.43	2.35	2.8	0.5	1.6	0.25	0.1
JK-SMD1210-700L-12	JX	3.0	3.43	2.35	2.8	0.5	1.6	0.25	0.1
JK-SMD1210-750L	JX	3.0	3.43	2.35	2.8	0.5	1.6	0.25	0.1
JK-SMD1210-750L-12	JX	3.0	3.43	2.35	2.8	0.5	1.6	0.25	0.1

### Recommended Solder Pad Layout Dimensions (mm)

Device	F	G	H
	Normal Value	Normal Value	Normal Value
1210 Series	1.0	2.0	2.5

### Electrical Characteristics

Model	V <sub>MAX</sub> (V)	I <sub>MAX</sub> (A)	I <sub>H</sub> (A)	I <sub>T</sub> (A)	P <sub>D</sub> (W)	Maximum Time-to-Trip		Resistance	
						Current	Time	R <sub>iMIN</sub>	R <sub>lMAX</sub>
						(A)	(Sec)	(Ω)	(Ω)
JK-SMD1210-150L	6.0	50.0	1.5	3.0	0.8	8.0	2.0	0.010	0.060
JK-SMD1210-150L-12	12.0	50.0	1.5	3.0	0.8	8.0	2.0	0.010	0.060
JK-SMD1210-175L	6.0	50.0	1.75	3.5	0.8	8.0	2.0	0.005	0.040

Shenzhen Jinrui Electronic Material Co., Ltd

TEL: +86-(0)755-26546327 29356619

Website: <http://www.jkpptc.com>

Add: Jinke Industry Park, No.310,Wuhe Road,Guanlan,Longhua District,Shenzhen,Guangdong,China.

*Specifications are subject to change without notice !*

FAX: +86-(0)755-26546562

E-mail: 1492037589@qq.com



JK-SMD1210-175L-12	12.0	50.0	1.75	3.5	0.8	8.0	2.0	0.005	0.040
JK-SMD1210-190L	6.0	50.0	1.9	3.8	0.8	8.0	3.0	0.006	0.037
JK-SMD1210-190L-12	12.0	50.0	1.9	3.8	0.8	8.0	3.0	0.006	0.037
JK-SMD1210-200L	6.0	50.0	2.0	4.0	0.8	8.0	3.0	0.006	0.035
JK-SMD1210-200L-12	12.0	50.0	2.0	4.0	0.8	8.0	3.0	0.006	0.035
JK-SMD1210-260L	6.0	50.0	2.6	5.2	0.8	13.0	2.0	0.003	0.025
JK-SMD1210-260L-12	12.0	50.0	2.6	5.2	0.8	13.0	2.0	0.003	0.025
JK-SMD1210-300L	6.0	50.0	3.0	6.0	0.8	15.0	2.0	0.003	0.02
JK-SMD1210-300L-12	12.0	50.0	3.0	6.0	0.8	15.0	2.0	0.003	0.02
JK-SMD1210-350L	6.0	50.0	3.5	7.0	0.8	17.5	2.0	0.002	0.018
JK-SMD1210-350L-12	12.0	50.0	3.5	7.0	0.8	17.5	2.0	0.002	0.018
JK-SMD1210-380L	6.0	50.0	3.8	7.6	0.8	19.0	2.0	0.002	0.016
JK-SMD1210-380L-12	12.0	50.0	3.8	7.6	0.8	19.0	2.0	0.002	0.016
JK-SMD1210-400L	6.0	50.0	4.0	8.0	0.8	20.0	2.0	0.002	0.014
JK-SMD1210-400L-12	12.0	50.0	4.0	8.0	0.8	20.0	2.0	0.002	0.014
JK-SMD1210-450L	6.0	50.0	4.5	9.0	1.0	22.5	2.0	0.001	0.013
JK-SMD1210-450L-12	12.0	50.0	4.5	9.0	1.0	22.5	2.0	0.001	0.013
JK-SMD1210-500L	6.0	50.0	5.0	10.0	1.0	25.0	2.0	0.001	0.012
JK-SMD1210-500L-12	12.0	50.0	5.0	10.0	1.0	25.0	2.0	0.001	0.012
JK-SMD1210-550L	6.0	50.0	5.5	11.0	1.0	27.5	2.0	0.001	0.011
JK-SMD1210-550L-12	12.0	50.0	5.5	11.0	1.0	27.5	2.0	0.001	0.011
JK-SMD1210-600L	6.0	50.0	6.0	12.0	1.2	30.0	2.0	0.001	0.010
JK-SMD1210-600L-12	12.0	50.0	6.0	12.0	1.2	30.0	2.0	0.001	0.010
JK-SMD1210-650L	6.0	50.0	6.5	13.0	1.2	32.5	2.0	0.001	0.009
JK-SMD1210-650L-12	12.0	50.0	6.5	13.0	1.2	32.5	2.0	0.001	0.009
JK-SMD1210-700L	6.0	50.0	7.0	14.0	1.2	35.0	2.0	0.001	0.008
JK-SMD1210-700L-12	12.0	50.0	7.0	14.0	1.2	35.0	2.0	0.001	0.008
JK-SMD1210-750L	6.0	50.0	7.5	15.0	1.2	37.5	2.0	0.001	0.007
JK-SMD1210-750L-12	12.0	50.0	7.5	15.0	1.2	37.5	2.0	0.001	0.007

### Thermal Derating Chart-I<sub>H</sub> (A)

Model	Maximum ambient operating temperature (°C)								
	-40	-20	0	25	40	50	60	70	85
JK-SMD1210-150L	2.25	2.00	1.75	1.50	1.33	1.15	1.05	0.93	0.70
JK-SMD1210-150L-12	2.25	2.00	1.75	1.50	1.33	1.15	1.05	0.93	0.70
JK-SMD1210-175L	2.55	2.33	2.02	1.75	1.53	1.35	1.23	1.07	0.85
JK-SMD1210-175L-12	2.55	2.33	2.02	1.75	1.53	1.35	1.23	1.07	0.85

Shenzhen Jinrui Electronic Material Co., Ltd

TEL: +86-(0)755-26546327 29356619

Website: <http://www.jkpptc.com>

Add: Jinke Industry Park, No.310,Wuhe Road,Guanlan,Longhua District,Shenzhen,Guangdong,China.

FAX: +86-(0)755-26546562

E-mail: 1492037589@qq.com

*Specifications are subject to change without notice !*



JK-SMD1210-190L	2.81	2.53	2.20	1.90	1.67	1.47	1.34	1.17	0.91
JK-SMD1210-190L-12	2.81	2.53	2.20	1.90	1.67	1.47	1.34	1.17	0.91
JK-SMD1210-200L	2.96	2.67	2.32	2.00	1.76	1.55	1.41	1.23	0.96
JK-SMD1210-200L-12	2.96	2.67	2.32	2.00	1.76	1.55	1.41	1.23	0.96
JK-SMD1210-260L	3.85	3.47	3.02	2.60	2.29	2.01	1.84	1.59	1.25
JK-SMD1210-260L-12	3.85	3.47	3.02	2.60	2.29	2.01	1.84	1.59	1.25
JK-SMD1210-300L	4.40	3.98	3.45	3.00	2.64	2.30	2.15	1.83	1.42
JK-SMD1210-300L-12	4.40	3.98	3.45	3.00	2.64	2.30	2.15	1.83	1.42
JK-SMD1210-350L	5.18	4.67	4.06	3.50	3.08	2.71	2.47	2.15	1.68
JK-SMD1210-350L-12	5.18	4.67	4.06	3.50	3.08	2.71	2.47	2.15	1.68
JK-SMD1210-380L	5.55	5.02	4.35	3.80	3.32	2.92	2.65	2.30	1.81
JK-SMD1210-380L-12	5.55	5.02	4.35	3.80	3.32	2.92	2.65	2.30	1.81
JK-SMD1210-400L	5.92	5.33	4.64	4.00	3.52	3.09	2.83	2.45	1.92
JK-SMD1210-400L-12	5.92	5.33	4.64	4.00	3.52	3.09	2.83	2.45	1.92
JK-SMD1210-450L	6.12	5.39	5.16	4.50	3.85	3.35	3.00	2.36	1.56
JK-SMD1210-450L-12	6.12	5.39	5.16	4.50	3.85	3.35	3.00	2.36	1.56
JK-SMD1210-500L	7.40	6.67	5.80	5.00	4.40	3.87	3.53	3.07	2.40
JK-SMD1210-500L-12	7.40	6.67	5.80	5.00	4.40	3.87	3.53	3.07	2.40
JK-SMD1210-550L	8.14	7.34	6.38	5.50	4.84	4.26	3.88	3.38	2.64
JK-SMD1210-550L-12	8.14	7.34	6.38	5.50	4.84	4.26	3.88	3.38	2.64
JK-SMD1210-600L	8.65	7.91	6.93	6.00	5.23	4.45	4.00	3.63	2.85
JK-SMD1210-600L-12	8.65	7.91	6.93	6.00	5.23	4.45	4.00	3.63	2.85
JK-SMD1210-650L	9.20	8.45	7.45	6.50	5.60	4.65	4.30	3.89	3.00
JK-SMD1210-650L-12	9.20	8.45	7.45	6.50	5.60	4.65	4.30	3.89	3.00
JK-SMD1210-700L	9.84	9.00	7.95	7.00	5.96	4.95	4.50	4.16	3.20
JK-SMD1210-700L-12	9.84	9.00	7.95	7.00	5.96	4.95	4.50	4.16	3.20
JK-SMD1210-750L	10.5	9.65	8.50	7.50	6.40	5.30	4.80	4.45	4.42
JK-SMD1210-750L-12	10.5	9.65	8.50	7.50	6.40	5.30	4.80	4.45	4.42

### Test Procedures and Requirements

Test Item	Test Conditions	Accept/Reject Criteria
Initial Resistance	In still air at 25°C	$R_{\text{MIN}} \leq R \leq R_{\text{MAX}}$
Time to Trip	Specified current, $V_{\text{MAX}}$ , 25°C	$T \leq$ Maximum Time to Trip
Holding Current	30min, at $I_{\text{H}}$ , 25°C	No trip
Trip Cycle Life	$V_{\text{MAX}}$ , $I_{\text{MAX}}$ , 100 cycles	No arcing or burning
Trip Endurance	$V_{\text{MAX}}$ , $I_{\text{MAX}}$ , 1 hour	No arcing or burning

Shenzhen Jinrui Electronic Material Co., Ltd

TEL: +86-(0)755-26546327 29356619

Website: <http://www.jkpptc.com>

Add: Jinke Industry Park, No.310,Wuhe Road,Guanlan,Longhua District,Shenzhen,Guangdong,China.

*Specifications are subject to change without notice !*

FAX: +86-(0)755-26546562

E-mail:1492037589@qq.com

**Physical Characteristics**

Terminal Materials	Tin-Plated Nickle-copper
Soldering Zone	Meets EIA specification RS 186-9E and ANSI/J-STD-002 Category 3.
Moisture Sensitivity	Level 2a, per IPC/JEDEC J-STD 020C

**Environmental Specifications**

Test Item	Test Conditions	Resistance Change
Passive Aging	85°C, 1000 hours	±10% typical
Humidity Aging	85°C/85%RH, 100 hours	±5% typical
Thermal Shock	MIL-STD-202, Method 107G +85°C/-40°C, 20 times	-30% typical
Solvent Resistance	MIL-STD-202, Method 215	No change
Vibration	ML-STD-883C, Test Condition A	No change

**Electrical Specifications**

$I_H$ =Hold current: Maximum current at which the device will not interrupt in 25°C still air.

$I_T$ =Trip current: Minimum current at which the device from low resistance to high resistance in 25°C still air.

$V_{MAX}$ =Maximum continuous voltage device can withstand without damage at rated current.

$I_{MAX}$ =Maximum fault current device can withstand without damage at rated voltage.

Maximum Time-to-trip: Maximum time to trip at assigned current.

$P_D$ =Typical power dissipation: Typical amount of power dissipated from the device when in 25°C still air environment.

$R_{iMIN}$ =Minimum resistance of device at 25°C prior to tripping.

$R_{I_{MAX}}$  = Maximum device resistance is measured one hour post reflow.

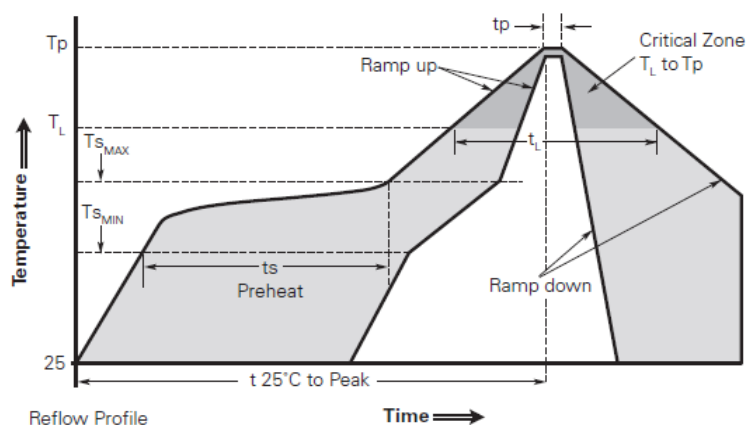
**Solder Reflow Profiles**

Profile Feature	Pb-Free Assembly
Average ramp up rate( $T_{S_{MAX}}$ to $T_p$ )	3°C/second max.
<b>Preheat</b>	
● Temperature min.( $T_{S_{MIN}}$ )	150°C
● Temperature max.( $T_{S_{MAX}}$ )	200°C
● Time ( $T_{S_{MIN}}$ to $T_{S_{MAX}}$ )	60-120 seconds
<b>Time maintained above:</b>	
● Temperature ( $T_L$ )	217°C
● Time ( $T_L$ )	60-150 seconds
<b>Peak/Classification temperature (<math>T_P</math>)</b>	260°C
<b>Time within 5°C of actual peak temperature</b>	
Time ( $T_P$ )	30 seconds max.
<b>Ramp down rate</b>	3°C/second max.
<b>Time 25°C to peak temperature</b>	8 minutes max.

- Recommended reflow methods: IR, vapor phase oven, hot air oven, N2 environment for lead-free.
- Devices are not designed to be wave soldered to the bottom side of the board.
- Recommended maximum paste thickness is 0.25mm (0.010inch).
- Devices can be cleaned using standard industry methods and solvents.

Note 1: All temperature refer to topside of the package,measured on the package body surface.

Note 2: If reflow temperature exceed the recommended profile,devices may not meet the performance requirements.

## Part Numbering System

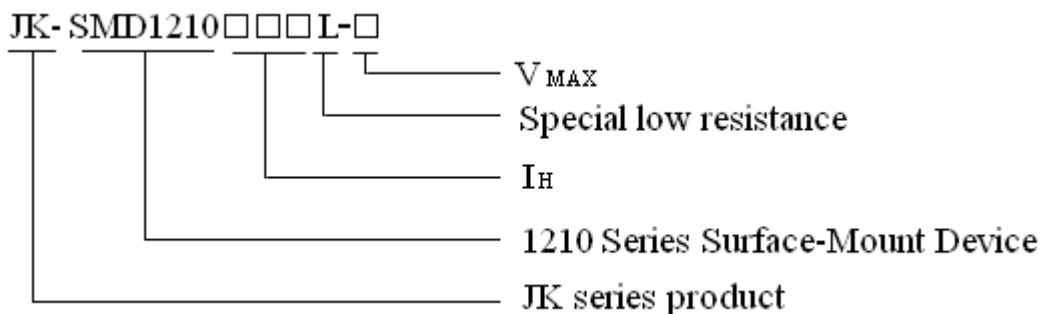

Tape Specifications and Reel Dimensions

Covering Specifications EIA 481-1	
W	8.0 ±0.3
P <sub>0</sub>	4.0 ±0.10
P <sub>1</sub>	4.0±0.10
P <sub>2</sub>	2.0 ±0.05
A <sub>0</sub>	2.82 ±0.10
B <sub>0</sub>	3.46 ±0.10
D <sub>0</sub>	1.55 ±0.05
F	3.50±0.05
E <sub>1</sub>	1.75 ±0.10
T	0.25 ±0.10
Leader min.	390
Trailer min.	160
Reel Dimensions	
A	178±1.0
N	59±1
W <sub>1</sub>	8.5+1.0/-0.2
W <sub>2</sub>	12.0±1

EIA Tape Component Dimensions

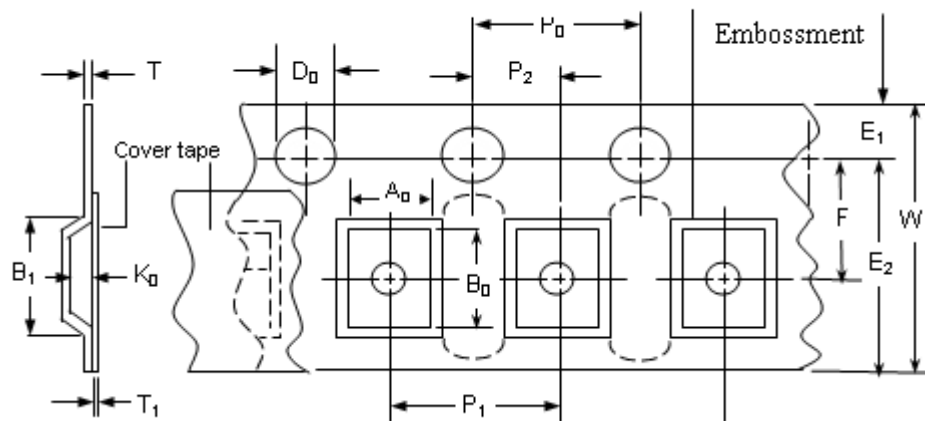

EIA Reel Dimensions

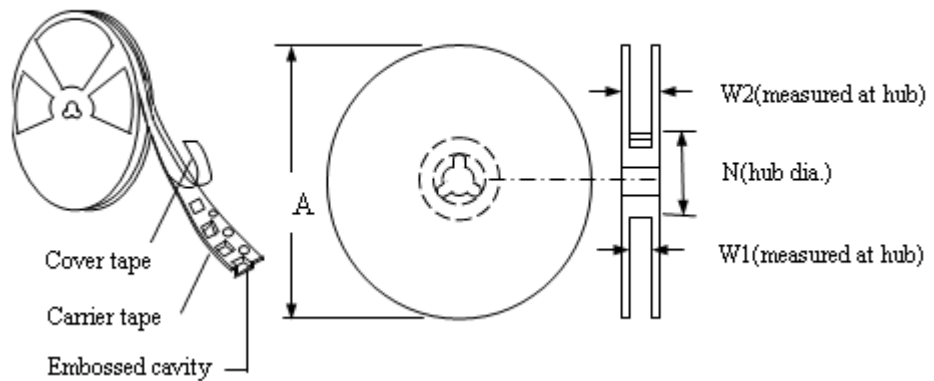

Packaging Quantity

Model	Quantity	Model	Quantity
JK-SMD1210-150L	4000	JK-SMD1210-400L	3000
JK-SMD1210-150L-12	4000	JK-SMD1210-400L-12	3000
JK-SMD1210-175L	4000	JK-SMD1210-450L	3000
JK-SMD1210-175L-12	4000	JK-SMD1210-450L-12	3000
JK-SMD1210-190L	4000	JK-SMD1210-500L	3000
JK-SMD1210-190L-12	4000	JK-SMD1210-500L-12	3000
JK-SMD1210-200L	4000	JK-SMD1210-550L	3000
JK-SMD1210-200L-12	4000	JK-SMD1210-550L-12	3000
JK-SMD1210-260L	4000	JK-SMD1210-600L	3000
JK-SMD1210-260L-12	4000	JK-SMD1210-600L-12	3000
JK-SMD1210-300L	4000	JK-SMD1210-650L	3000



JK-SMD1210-300L-12	4000	JK-SMD1210-650L-12	3000
JK-SMD1210-350L	3000	JK-SMD1210-700L	3000
JK-SMD1210-350L-12	3000	JK-SMD1210-700L-12	3000
JK-SMD1210-380L	3000	JK-SMD1210-750L	3000
JK-SMD1210-380L-12	3000	JK-SMD1210-750L-12	3000

## Storage

The maximum ambient temperature shall not exceed 40°C. Storage temperatures higher than 40°C could result in the deformation of packaging materials. The maximum relative humidity recommended for storage is 70%. High humidity with high temperature can accelerate the oxidation the oxidation of the solder plating on the termination and reduce the solderability of the components. Sealed plastic bags with desiccant shall be used to reduce the oxidation of the termination and shall only be opened prior to use, the products shall not be stored in areas where harmful gases containing sulfur or chlorine are present.

## Warning

- Please read this specification before using the product.
- Use PPTC beyond the maximum ratings or improper use may result in device damage, electrical arcing and flame.
- PPTC are intended for protection against occasional over current or over temperature fault conditions and should not be used when repeated fault conditions or prolonged trip events are anticipated.
- Device performance can be impacted negatively if devices are handled in a manner inconsistent with recommended electronic, thermal, and mechanical procedures for electronic components.
- Use PPTC with a large inductance in circuit will generate a circuit voltage above the rated voltage of the PPTC.
- Avoid impact PPTC device its thermal expansion like placed under pressure or installed in limited space.
- Contamination of the PPTC material with certain silicon based oils or some aggressive solvents can adversely impact the performance of the devices. PPTC can be cleaned by standard methods.
- Requests that customers comply with our recommended solder pad layouts and recommended reflow profile. Improper board layouts or reflow profile could negatively impact solderability performance of our devices.

## Notes

The specification is intended to present application product and technical data to assist the user in selecting PPTC circuit production devices, However, users should independently evaluate and test the suitability of each product. Jinrui makes no warranties as to the accuracy or completeness of the information and disclaims any liability resulting from its use, Jinrui's only obligations are those in the Jinrui Standard Terms and Conditions of Sale and in no case will Jinrui be liable for any incidental, indirect, or consequential damages arising from the sale, resale, or misuse of its products. Jinrui reserves the right to change or update any information contained in this specification without notice.